

SAILS_{ETC}

141 High Street, Kelvedon, Essex, England. CO5 9AA
sales@sailsetc.com www.sailsetc.com

fax + 44 (0) 1376 571437
tel + 44 (0) 1376 570583

SAILSetc Catalogue Number

14D

Fitting Description **ball raced gooseneck/kicking strap** Drawing Code **PI 14D** copyright SAILSetc 2019

Applications **A Class & other boats of 10 – 20 kgs (Cat No 14D)**

Contents 1 gooseneck/kicking strap unit

If you would prefer not to use this boom end, please return it and ask for item 103BR-120 (to fit into 12 mm carbon tube with a 10 mm internal diameter boom) or a straight boom end fitting of carbon.

The design of the boom end may vary from the illustration. It has a 25 mm step in it so that (in the A Class) additional un-measured sail area can be made use of. It is designed to be glued using epoxy resin to the 14 mm diameter carbon tube main boom. Use 24 hour curing epoxy resin and ensure the matching surfaces of the end of the main boom and the boom end fitting are properly abraded before bonding. To meet the class rules it needs to be faired into the rest of the boom so, if it does not, use epoxy filler to smooth the transition between this item and the rest of the boom.

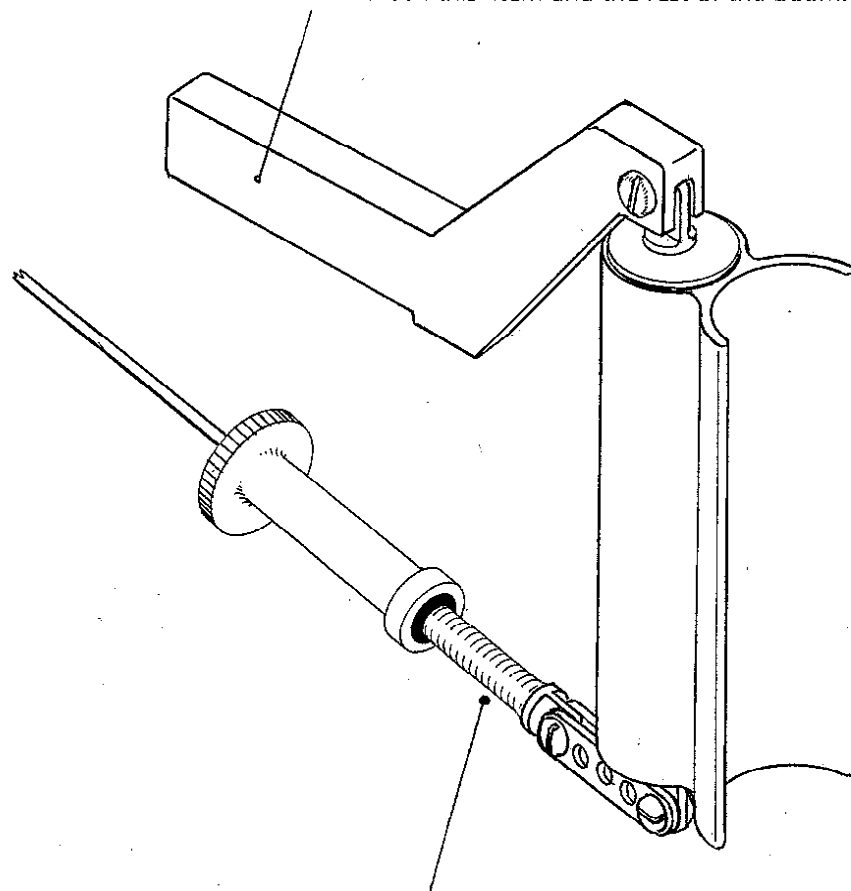

This version of the gooseneck/kicking strap unit has a simple kicking strap that works in tension only.

The body of the gooseneck is formed from carbon fibre and epoxy resin. It is intended that it shall be glued to the mast using epoxy resin. Use 24 hour curing epoxy resin and ensure the matching surfaces of the gooseneck body and mast are properly abraded before bonding. Check that the fitting is properly aligned with the mast before the glue hardens. Do this by removing the shaft and bearings from the body before bonding it and sighting down the hole in the body. If the mast is straight it should be aligned with the top of the mast.

If you are doubtful of the quality of the bond between gooseneck body and mast you can use 75 kg Dyneema to tie the body to the mast as shown. Check that the Dyneema does not foul the shaft of the gooseneck inside the body.

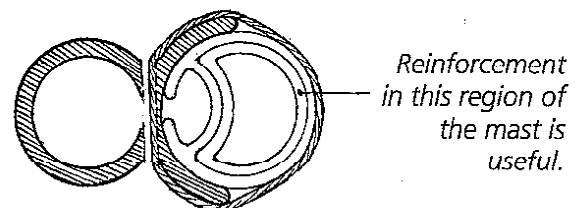

Not shown here - attachment of the kicking strap wire to the boom requires some care. The loads will be large and a simple hook will easily strip out of a hole in the boom. The boom thickness should be at least 2 mm if you are going to rely on a hook/hole attachment. Wrapping the boom with carbon tow and epoxy resin is a wise precaution.